

Guide, types, design, rigidity

Petr Zelený – Production Machines I

26. 9. 2014

Guide, types, design, rigidity

Guide allows direct movements of machine parts, e.g. machine tool carriage.

Guide must have the following characteristics :

- **High precision straightness track, secured low backlash and high rigidity,**
- **Possibility of setting guide backlash,**
- **Low friction and low wear,**
- **If possible, good vibration damping capability,**
- **Simple maintenance and lubrication,**
- **Protection against dirt and chips.**

Guide, types, design, rigidity

Types of guides according to the shape (profile) of the guide track :

- Flat,
- V-guide,
- Prismatic,
- Cylindrical (circular).

Guide, types, design, rigidity

Types of guides according to direction of loads:

- Open,
- Close.

Guide, types, design, rigidity

Types of guides according to type of friction:

- **Rolling,**
- **Sliding,**
- **Combination,**
- **another.**

Guide, types, design, rigidity

Flat guide

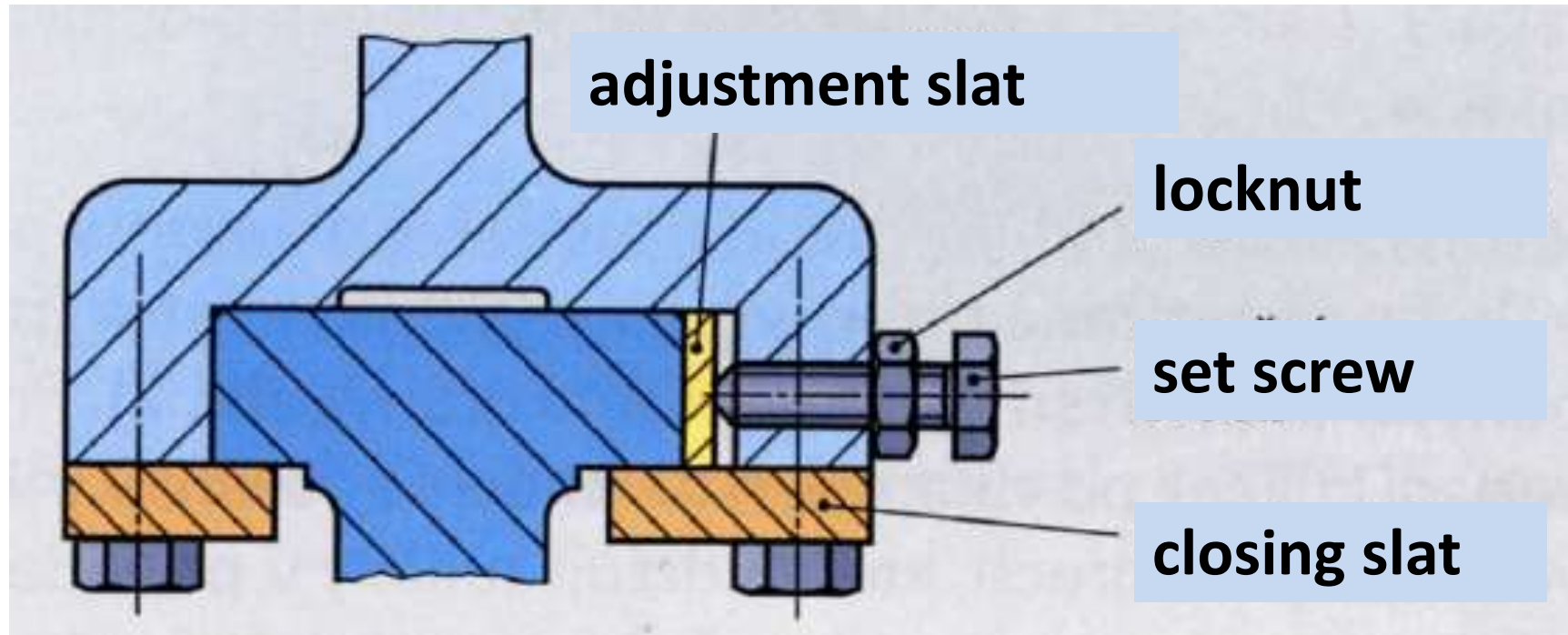

Guide, types, design, rigidity

V-guide, combination

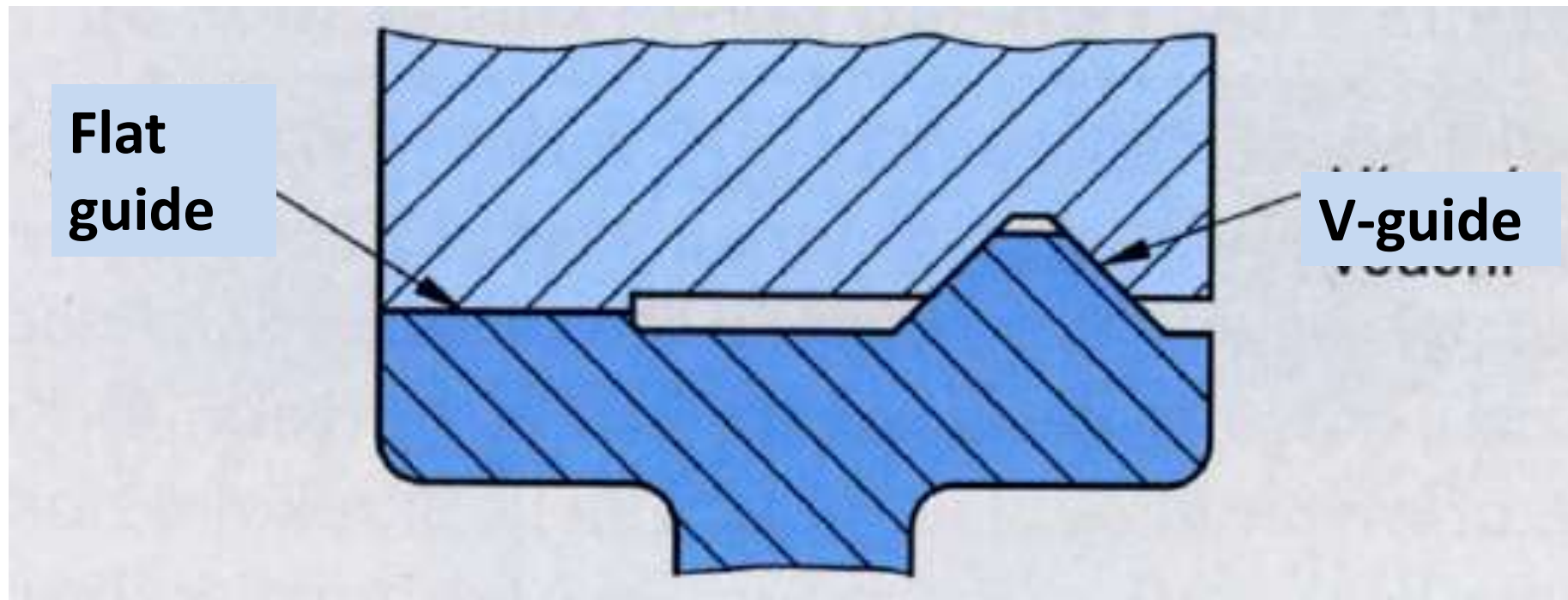

Guide, types, design, rigidity

Prismatic guide

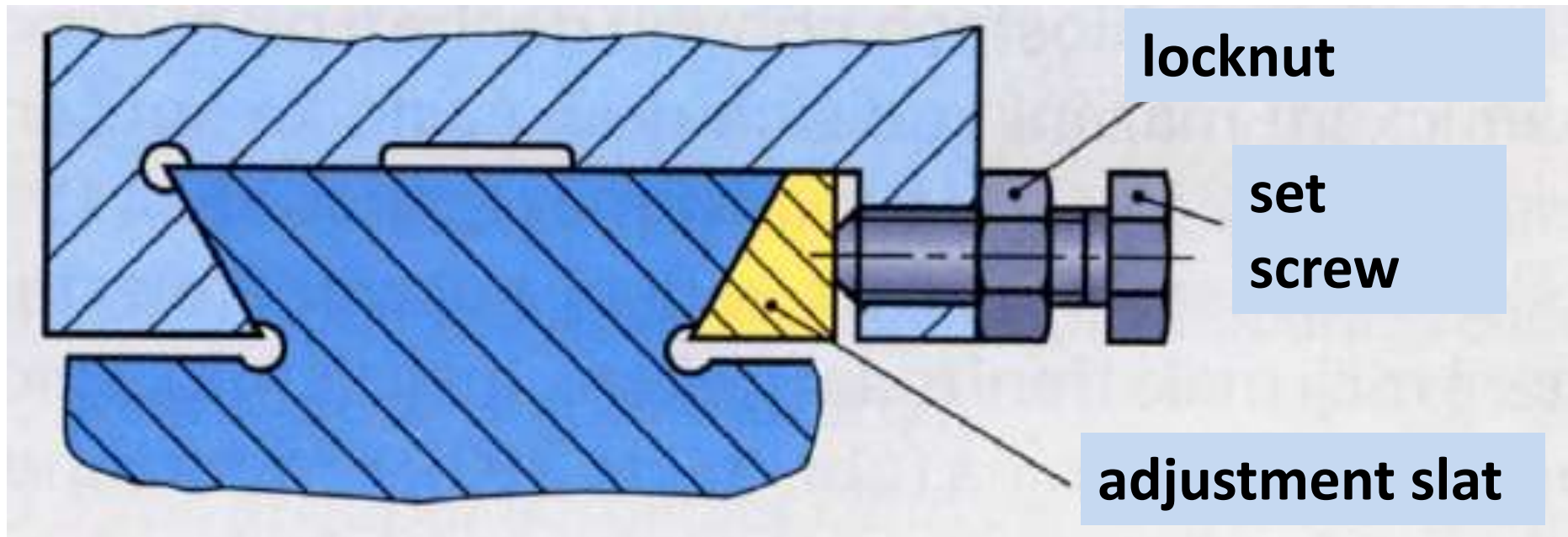

Guide, types, design, rigidity

Cylindrical guide

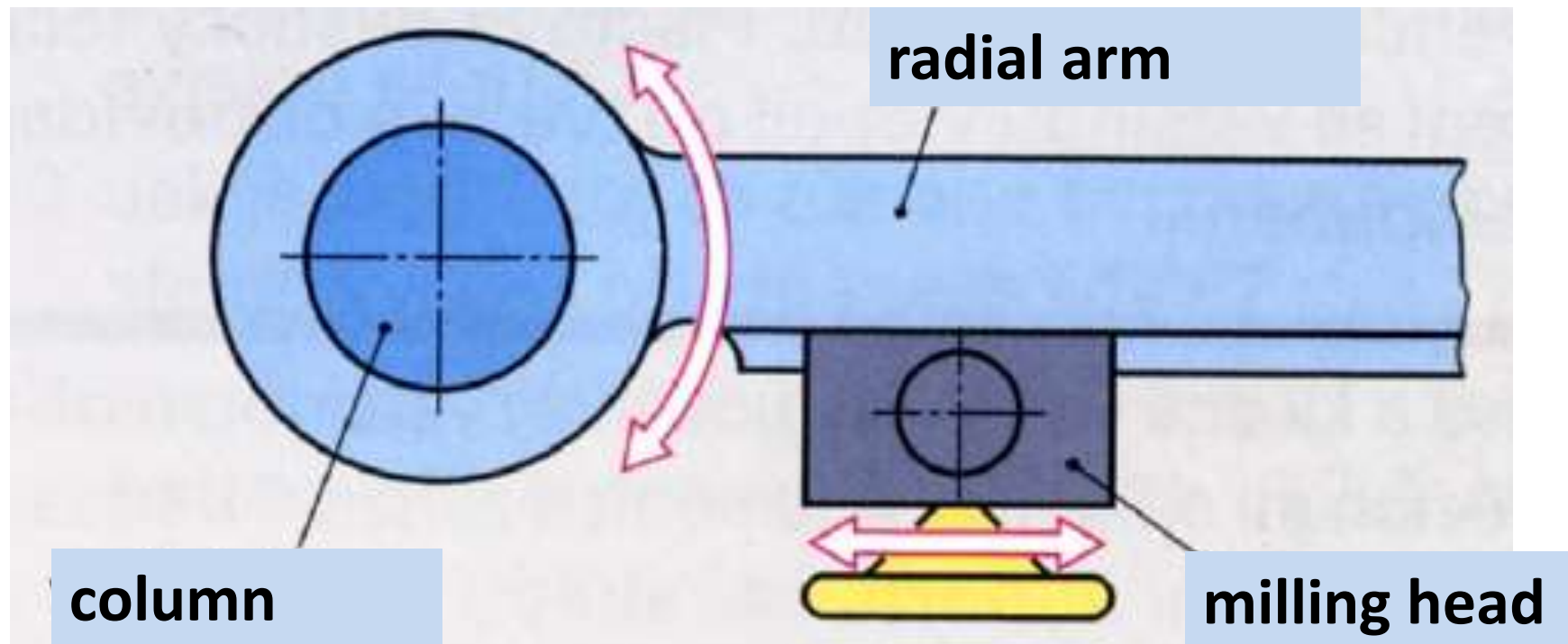

Guide, types, design, rigidity

Open guide

Open guideway can detect force acting on the guide portion only in directions perpendicular to the plane of the main guide surface (vertically or obliquely downward). Combined open guide can capture large forces perpendicular to the main surface of the lead, but little lateral strength.

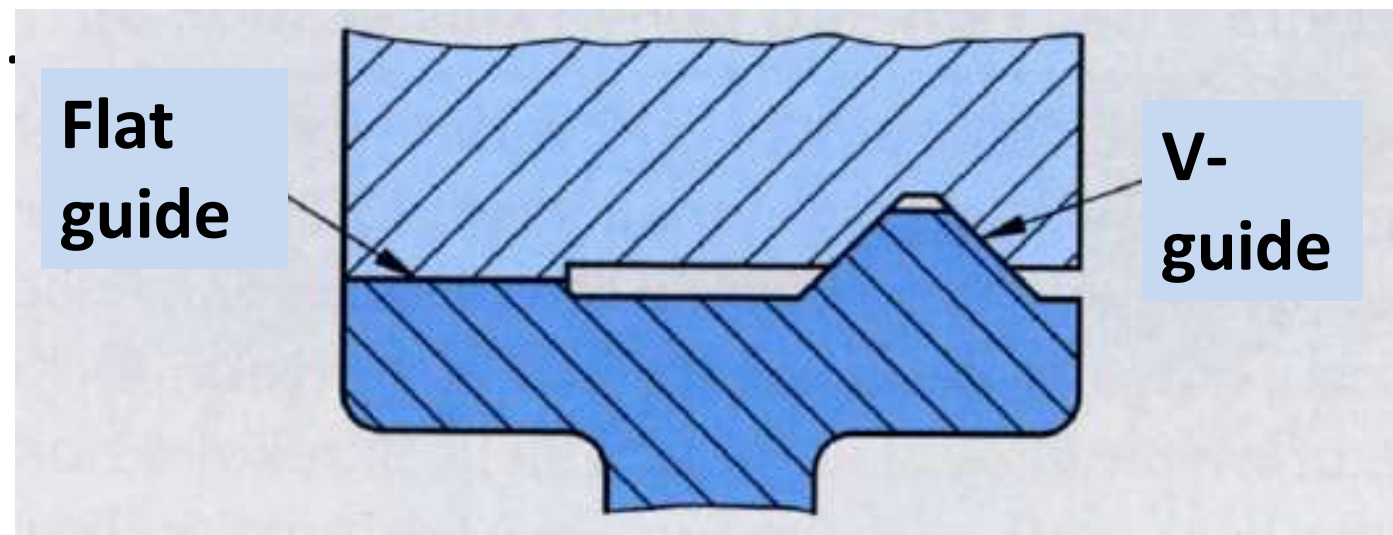

Guide, types, design, rigidity

Close guide

Captures forces in all directions perpendicular to the direction of guidance.

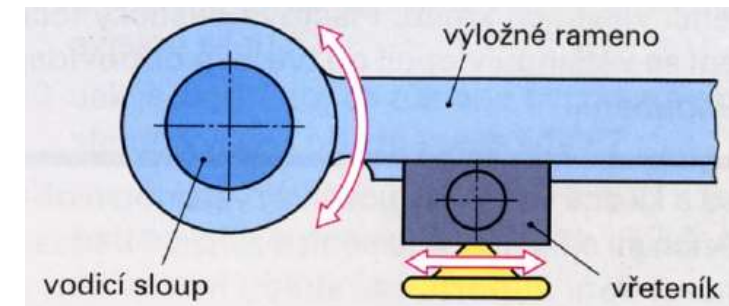
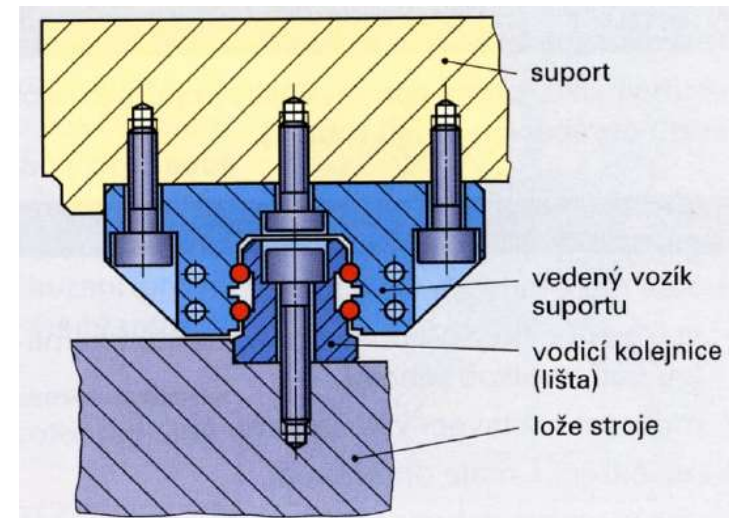
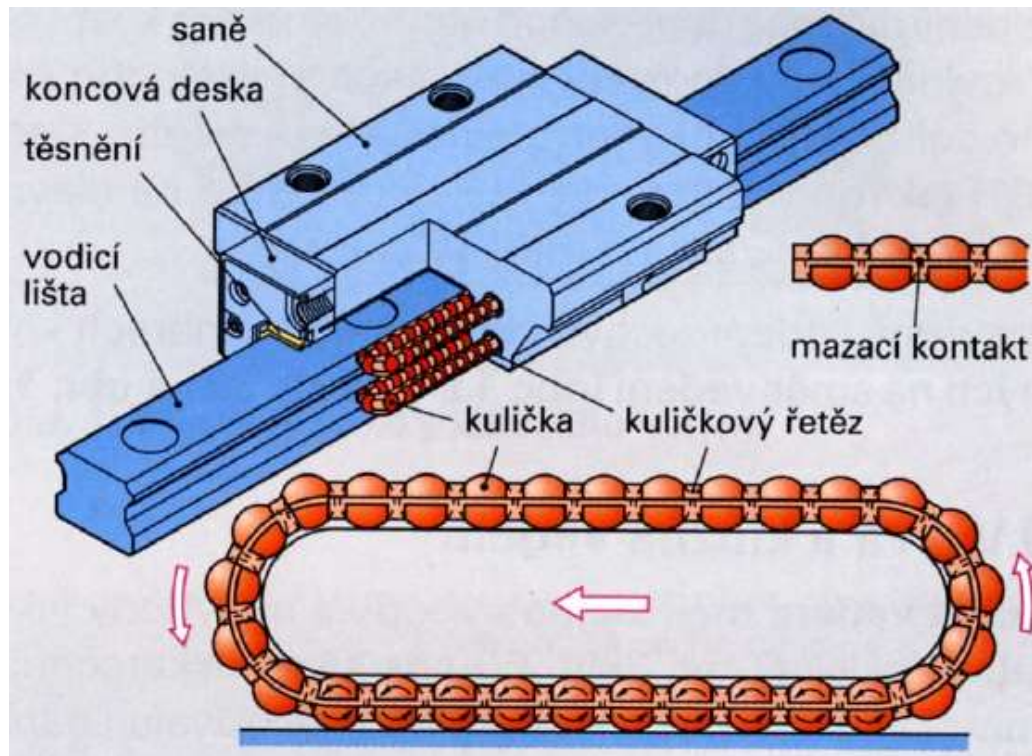

Guide, types, design, rigidity

Rolling line guide

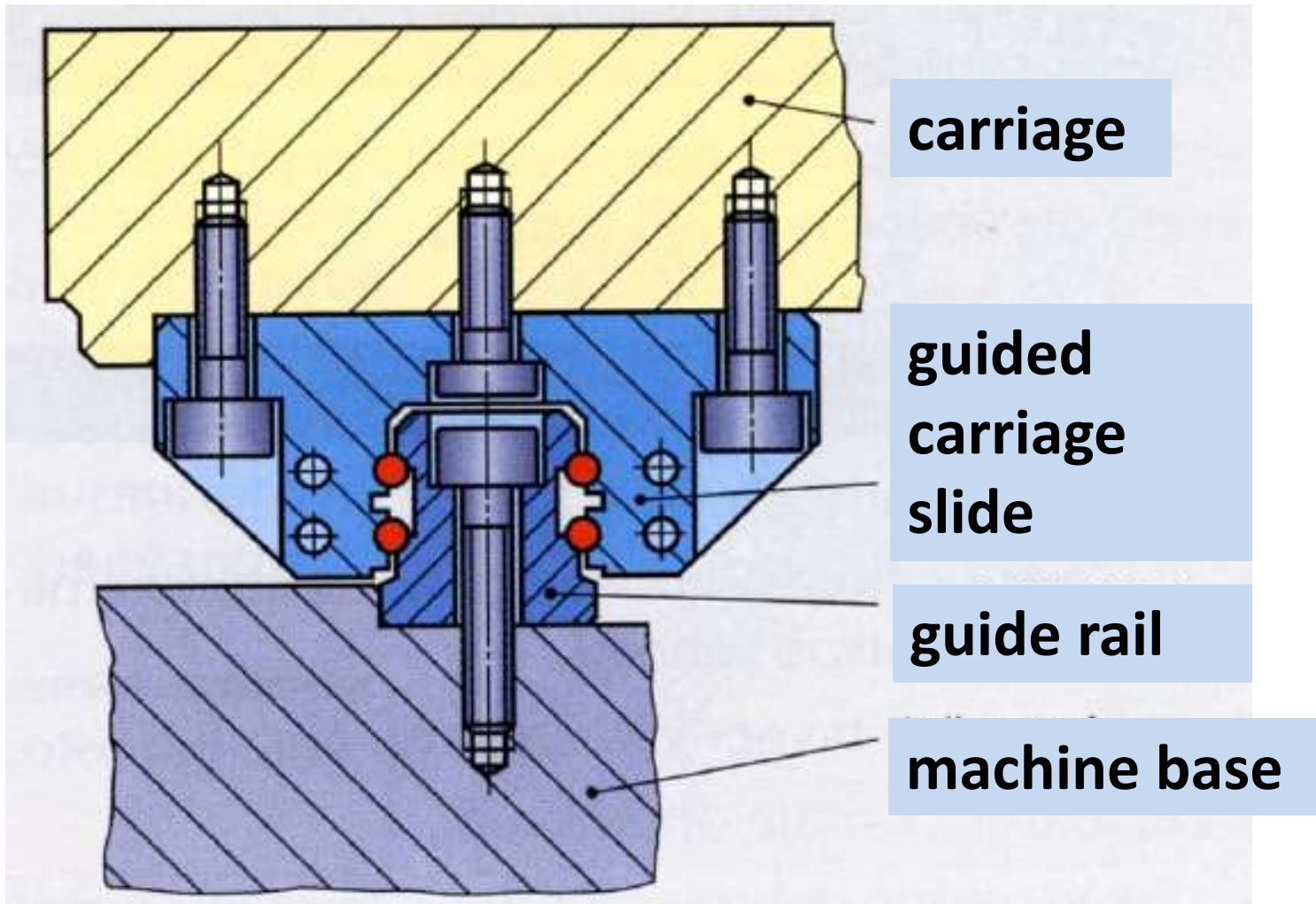

Guide, types, design, rigidity

Rolling line guide

In cases of long guide, rolling elements after the run of loaded tracks are returning back to the beginning of the loaded track.

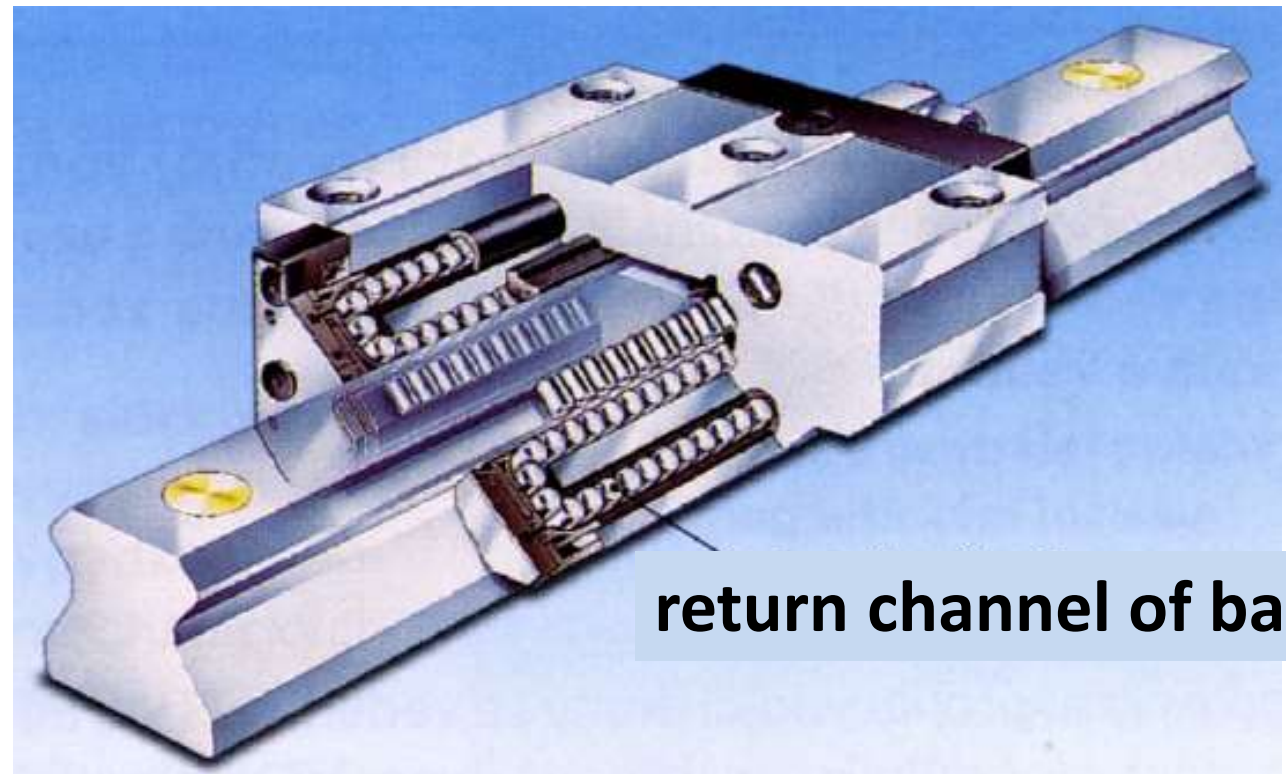

return channel of balls

Guide, types, design, rigidity

Rolling pulley guide

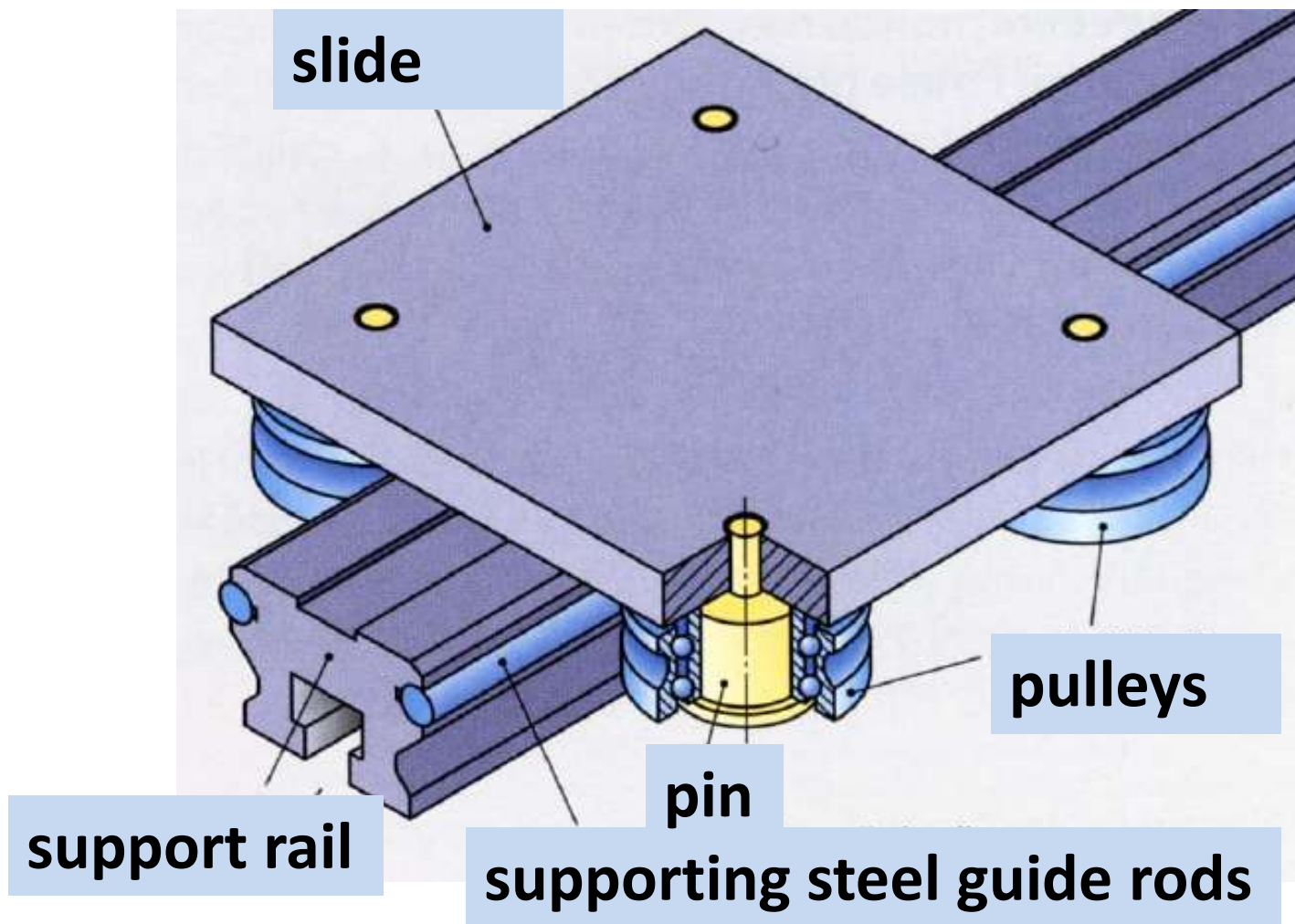

Guide, types, design, rigidity

Friction guide

For machine tools are often use guide coated with plastic (e.g. Teflon), having damping ability and are inexpensive. Static coefficient of friction is the same as dynamic. This eliminates jerking.

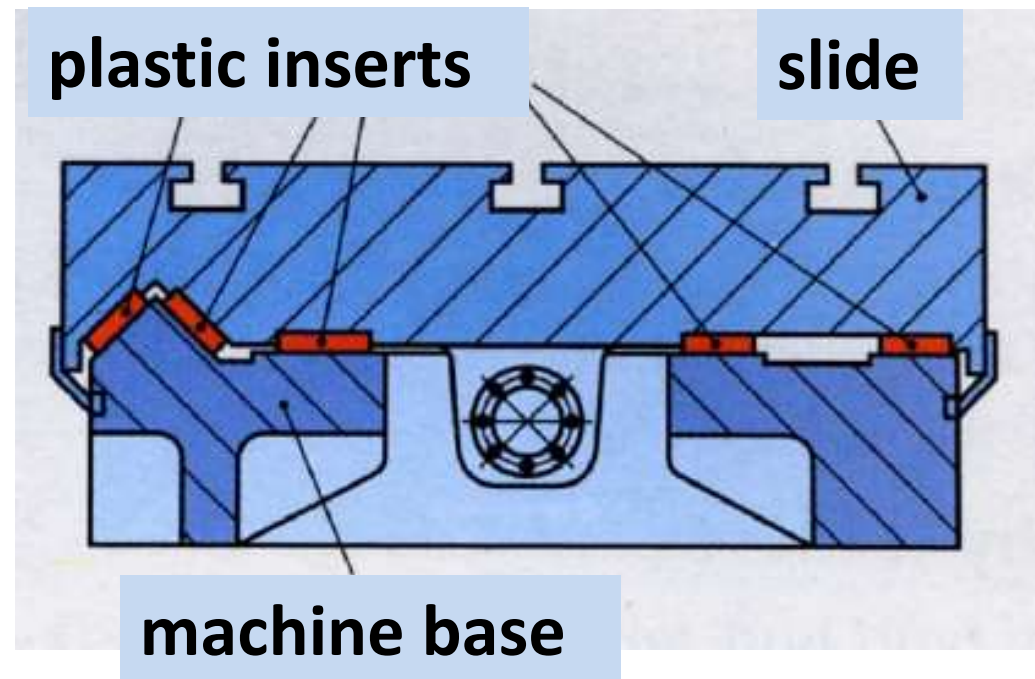

Guide, types, design, rigidity

Hydrostatic friction guide

Moving almost without friction. Eliminated jerking.

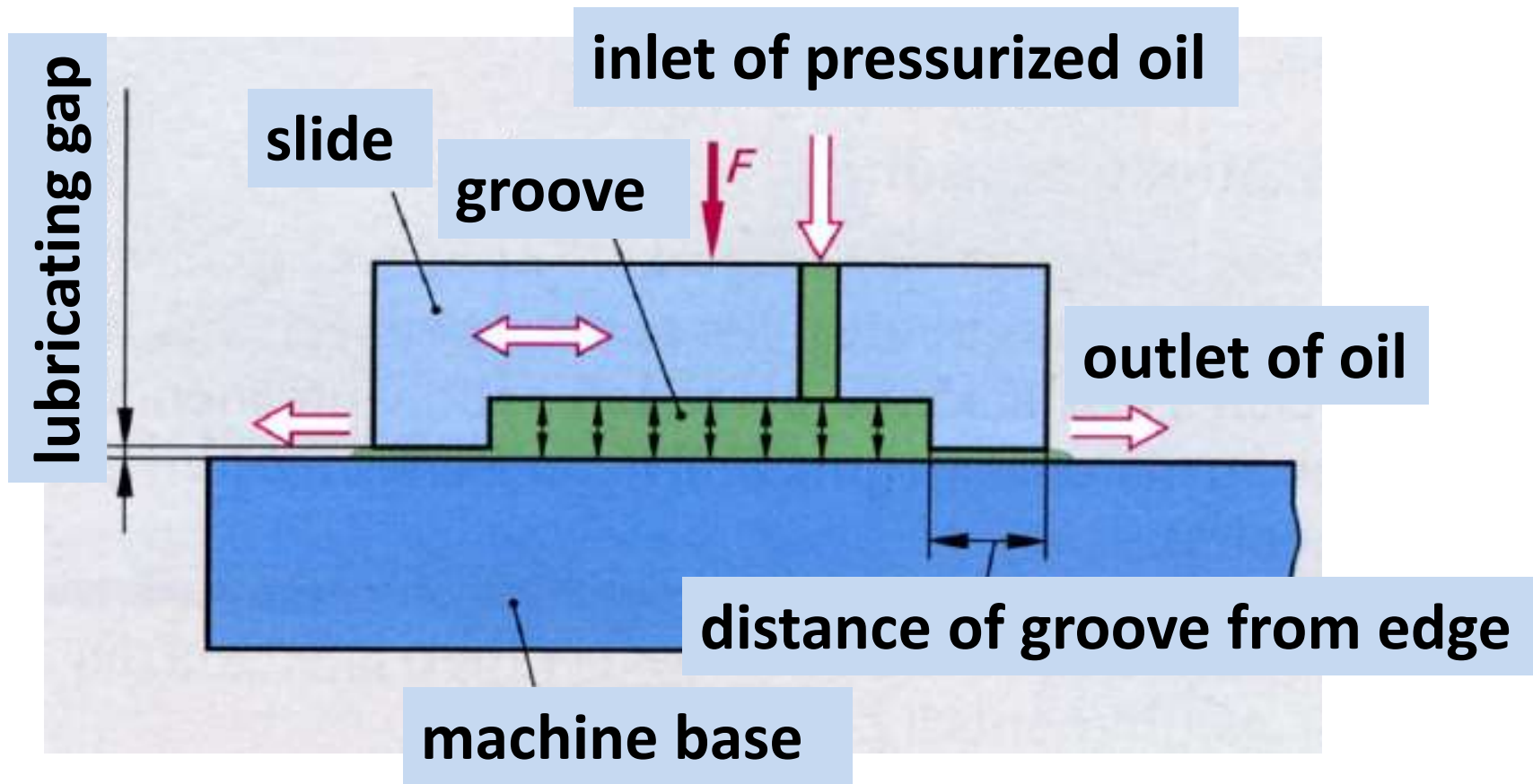

Guide, types, design, rigidity

Hydrostatic friction guide

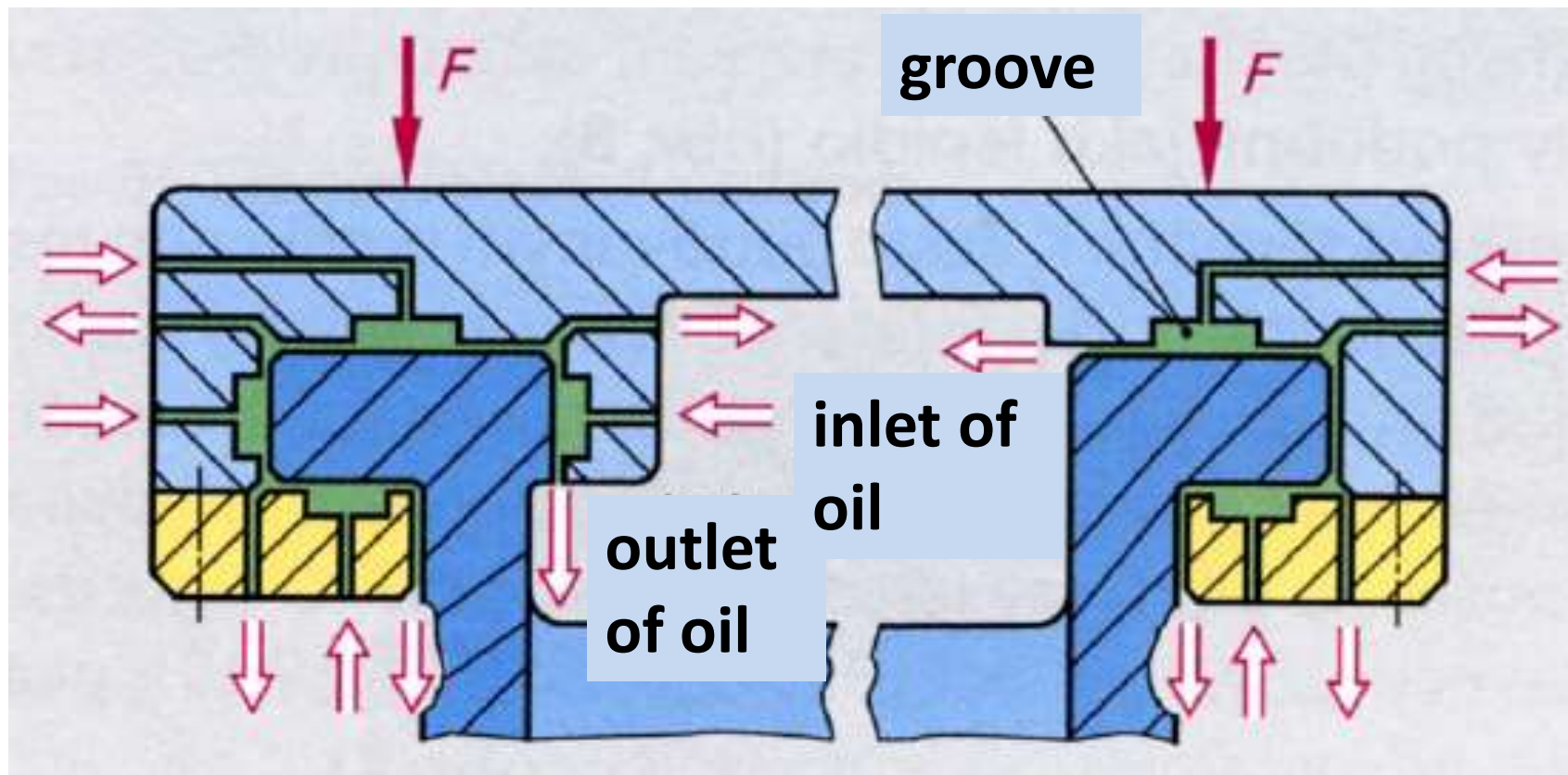

Guide, types, design, rigidity

Aerostatic friction guide

Instead of oil pressure is compressed air. Friction smaller than the hydrostatic lubrication. Without jerking.

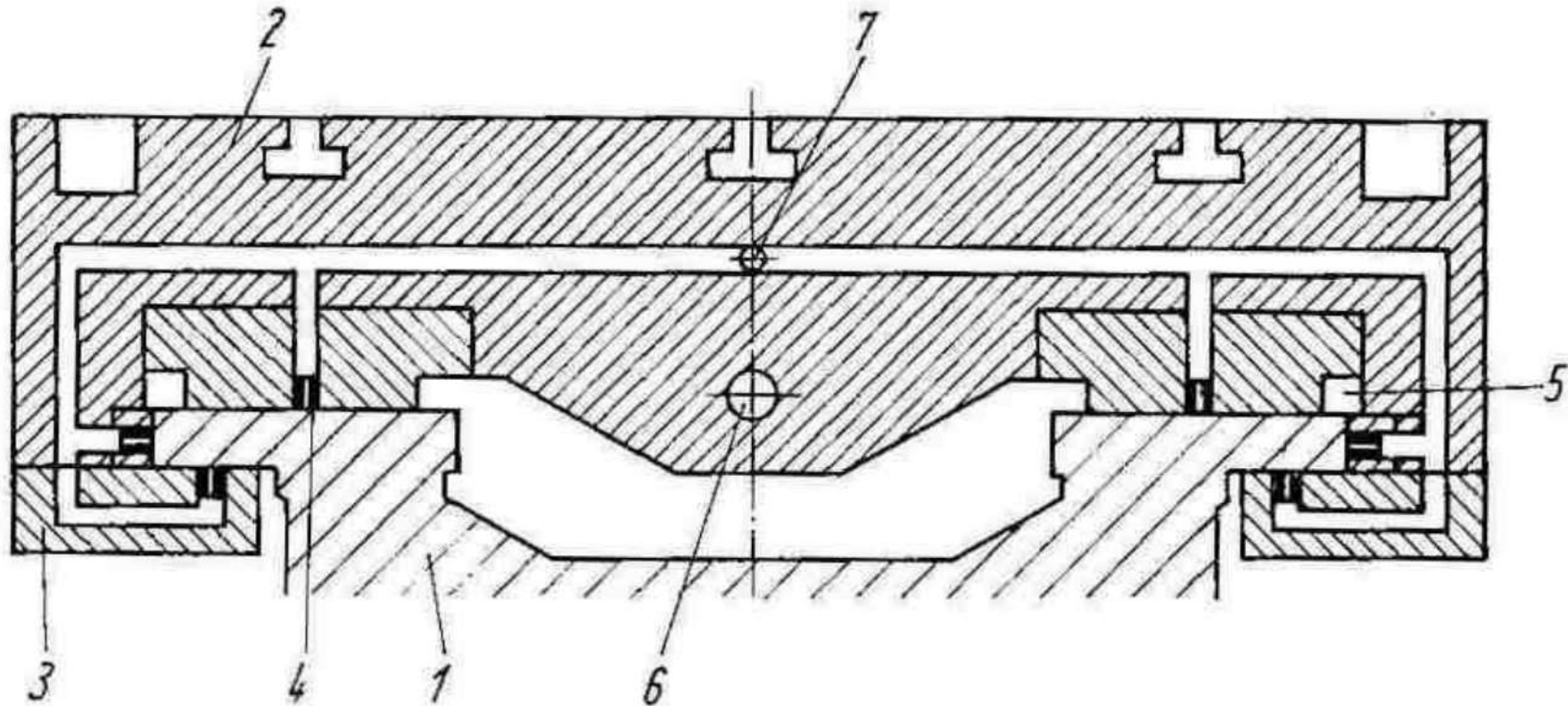

Guide, types, design, rigidity

Aerostatic friction guide

Rotary table with aerostatic bearings.

